

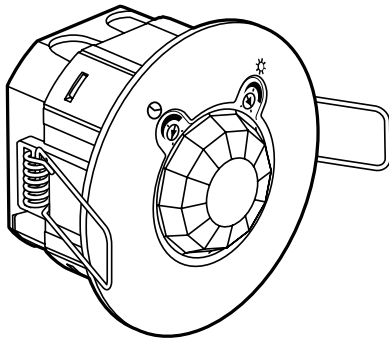

360° PIR Movement Sensor

Cat No. 630R02WE, 630S02WE

Instruction Manual



630R02WE

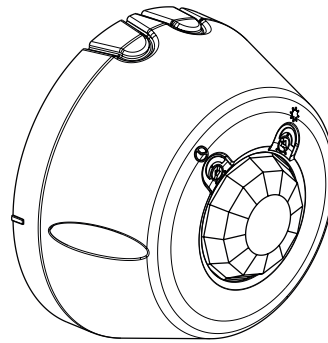

630S02WE

This product must be installed by a licensed electrician.

1. Specifications

Detection method	Passive Infrared (PIR)	
Supply voltage	230-240V a.c. 50Hz	
Terminal wiring size	1x2.5mm ² to 2x1.5mm ²	
Standby power	0.6W	
Detection/View angle	360°	
Detection range (ceiling height 2.5m)	Ø8m	
Lux adjustment range	10lux – 1275lux	
Time adjustment range	10sec – 10min (approximately)	
Switching function	Auto Mode only	
Overall dimensions	630R02WE	630S02WE
Cut-out size	Ø65mm	n.a.
Fascia size	Ø78mm	Ø90mm
Depth	50.5mm (overall) 39mm (into ceiling)	
Mounting centres	n.a.	79mm
IP rating	IP41	IP20
Weight	71g	90g

Maximum Lighting Load	
Incandescent	1000W (4.3A)
Fluorescent	360W (2.1A)
Extra low voltage halogen	500VA (2.1A)
Compact Fluorescent Lamp (CFL)	250VA (1.1A)
LED	250W (1.1A)

Fig. 1

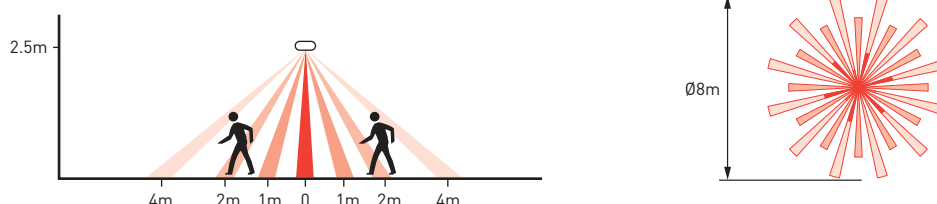

2 Sensor locations to be avoided

1. Near water features such as swimming pools or ponds. The movement and reflections are likely to create nuisance switching.
2. Near heat sources such as air conditioners, dryers, heaters or barbecues.
3. Locations which are subject to drastic changes in temperature.
4. Locations which are subject to bright light such as direct sunlight.
5. Locations frequented by animals such as pets or birds.

3 Installation

Switch off power source before installation. Ensure the power supply wiring comes from a circuit protected by a suitable fuse or circuit breaker. We recommend installing a wall switch for electrical isolation of the sensor. Refer to Fig. 3.

With reference to Fig. 2,

1. Remove the screw from the terminal block cover.
2. Connect wiring from power supply and load to the terminal block as marked. Refer to Fig. 3.
N: Neutral L: Active / Line 1: Load
3. Close the terminal block cover and re-do the screw. Ensure no bare wires are exposed.
4. Fold back spring clips and insert sensor into the ceiling cut-out (630R02WE) or surface mount on the ceiling (630S02WE).

Fig. 2
630R02WE

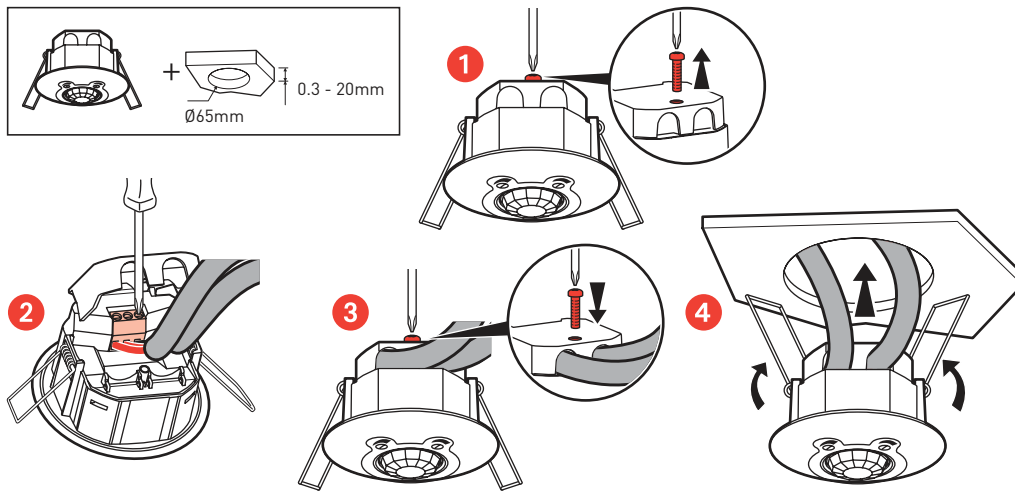

Fig. 2
630S02WE

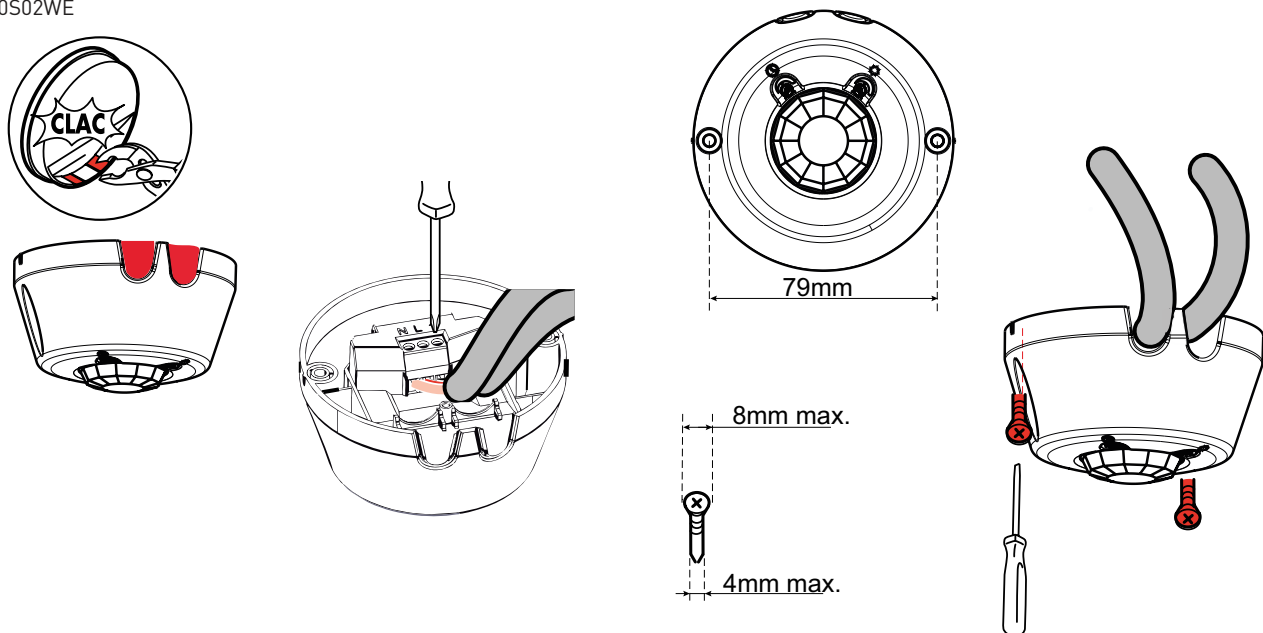
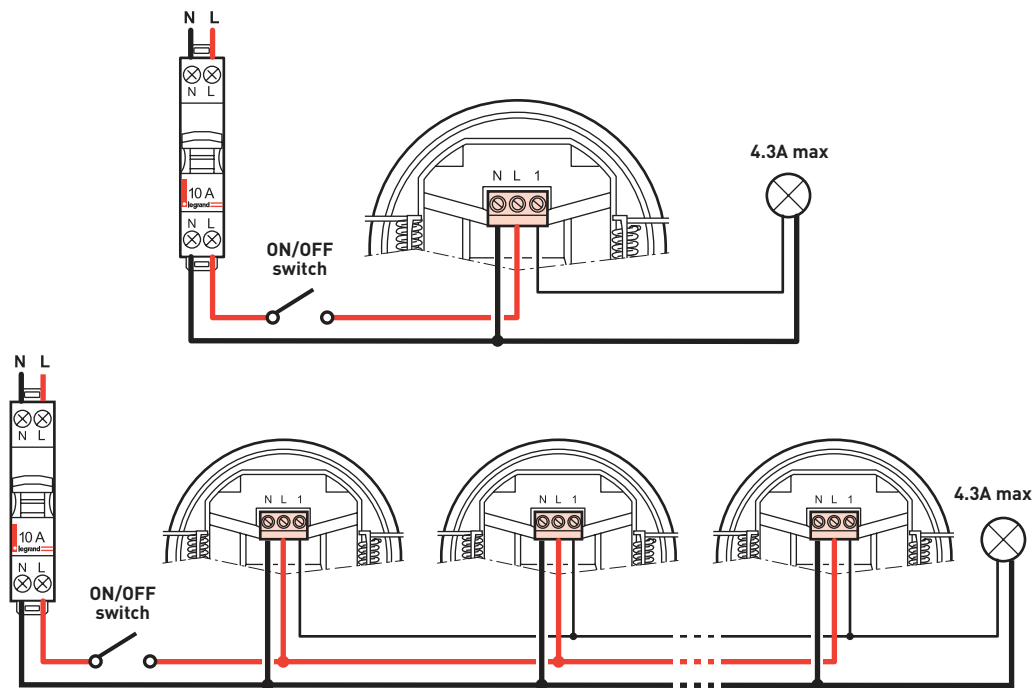
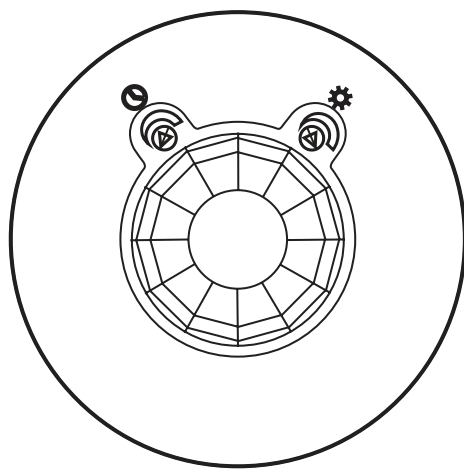

Fig. 3



4 Setting the controls

Fig. 4



Dial settings show
TEST MODE

With the Sensor fully installed by an electrician and power on

1. Turn the TIME knob to minimum and turn the LUX knob to light as shown in Fig. 4.
2. Turn the wall switch on. The light/s should turn on immediately and will remain on while the sensor warms up, for approximately 30 seconds. It will then turn off.
3. Walk through the coverage area and the light should turn on. This confirms that the wiring is correct and that the light is operational.
4. Adjust the TIME knob to your desired setting.
5. To set the ambient light level at which the sensor will switch on, turn the LUX knob to its fully anti-clockwise position. Wait for the desired ambient light level, then turn the LUX knob clockwise while someone walks through the coverage area. When the light switches on, release the LUX knob.

5 Time Adjustment

The TIME knob controls how long the light/s will stay on after movement is detected. Rotating the TIME knob clockwise increases the duration time. The duration time varies between approximately 10 seconds (minimum) to approximately 10 minutes (maximum).

Note: Once the light has been triggered by the PIR sensor, any subsequent detection will start the timed period again from the beginning.

6 Lux Adjustment

The LUX knob controls the ambient light level at which the sensor will switch on. At the fully clockwise position, the sensor will operate 24 hours a day. At the fully anti-clockwise position, the sensor will only operate at night. You can set the sensor to operate at the desired lux level by adjusting the LUX knob.

7 Maintenance / Cleaning

This product should only be cleaned with a damp cloth. Cleaning agents and solvents should not be used.

8 Troubleshooting

PROBLEM	POSSIBLE CAUSE	POSSIBLE SOLUTION
Light does not switch on when there is movement in the coverage area.	1. Power not available	Check connections, switches and fuse.
	2. Faulty light/globe.	Replace light/globe.
	3. Incorrect wiring.	Recheck all wiring.
	4. Controls set incorrectly.	Change light adjustment (LUX knob).
	5. Nearby lighting is too bright.	Relocate the unit.
Light switches on for no apparent reason (False triggering).	1. Heat sources (such as air conditioner, heater, dryer or barbecue) are activating the sensor.	Relocate the unit.
	2. Animals (birds, pets etc)	Possibly unavoidable.
	3. Interference on the same circuit from on/off switching of other electrical devices.	a. Check/Replace faulty switches. b. Replace noisy fluoro tubes/starters. c. Connect the unit to a different circuit.
	4. Reflective objects (such as swimming pool) in the coverage area.	Relocate the unit.
Light does not switch off after set time has elapsed.	1. Time is set for too long.	Reduce time (TIME knob).
	2. Wiring is incorrect.	Recheck all wiring.
	3. Unit damaged due to maximum load exceeded or incompatible load type or failure of the load (such as short circuit).	Identify and fix the cause of the failure. Replace the unit with a new one.
Light switches on during daylight.	1. LUX knob is set to daylight position.	Turn the LUX knob anti-clockwise to suit desired light setting.
When setting the controls in daylight the detection distance becomes shorter.	1. Interference by sunlight.	Re-set controls at night.

9 Disclaimers

1. This product must be installed and used as per these instructions.
2. The IP rating of this product is only valid when installed on a flat and non-porous surface. Additional sealing may be required for irregular surfaces.
3. This product must be used with the loads specified only. Other load types should be used only when written confirmation is given by HPM Legrand.
4. This product contains no serviceable parts and no attempt should be made to repair this product. If the product is faulty it should be discarded.
5. This product is not suitable for installation in hazardous and/or corrosive areas.
6. Electrical installations periodically receive transient over voltages. This product has been designed to minimise the effect of such voltages on connected equipment. It may not give full protection for extreme over-voltage transients such as those resulting from a close lighting strike.
7. This product utilises intellectual property in the form of registered designs, trademarks, and/or patents. Such intellectual property remains the property of HPM Legrand in all cases.
8. This product has been designed to operate in ambient temperatures -5°C to 45°C.
9. Extended exposure to UV rays (such as exposure to direct sunlight) may cause discolouration of this product.
10. The material in this product may vary in colour from batch to batch. Colour matching from one batch to another cannot be guaranteed.
11. HPM Legrand reserves the right to modify the specification of this product at any time.

Warranty

HPM Legrand warrants this product for a period of 3 years from the date of purchase.

These goods come with guarantees that cannot be excluded under the Australian and New Zealand Consumer Laws. You are entitled to a replacement or a refund for a major failure and for compensation for any other reasonably foreseeable loss or damage. You are also entitled to have the goods repaired if the goods fail to be acceptable quality and the failure does not amount to a major failure.

See the Warranty card enclosed with this product for further details.

Customer Service

For all Customer Service and Technical Support please call Monday to Friday during business hours.

HPM Legrand Australia
1300 369 777
www.hpm.com.au

HPM Legrand New Zealand
0800 476 009
www.hpm.co.nz

ABN: 31 000 102 661

A Group Brand | 